

SEARLE CONDENSER MGC134H-EC615-AV

DO NOT SCALE

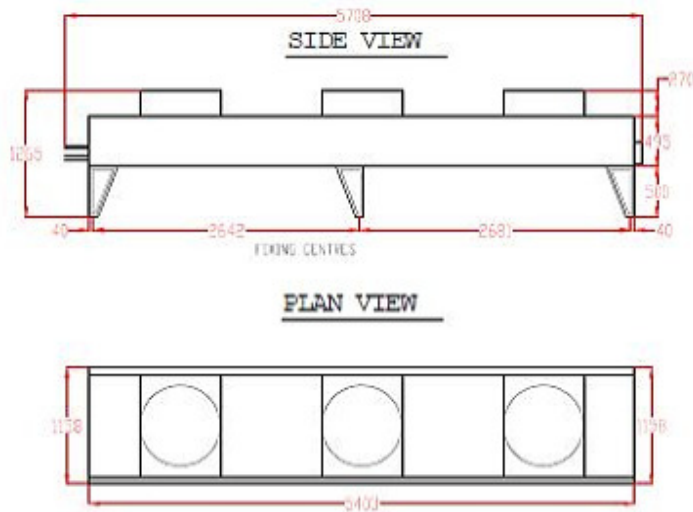

WEIGHT = 627kg/ UNIT

325 rpm - 34 dbA Night set
back max. condition
615 rpm - 47 dbA Full
daytime design

NEW CONDENSER	WIDTH	HEIGHT	LENGTH	WEIGHT	DB(A) @10M
SEARLE MGC134H-EC615-AV	1158MM	1265MM	5403MM	627KG	34 DB(A) 47 DB(A)
NEW CONDENSING UNIT	WIDTH	HEIGHT	LENGTH	WEIGHT	DB(A) @10M
SEARLE N2CQ76-3MS-E	2260MM	1192MM	600MM	273KG	45 DB(A)

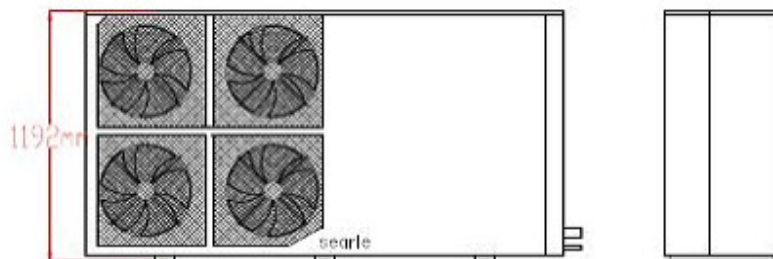
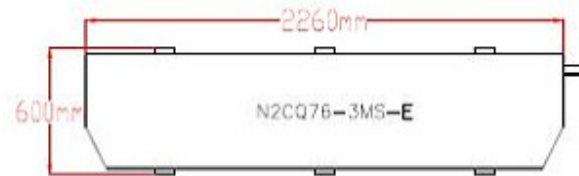

HUBBARD HT 8 COMPRESSOR

INTERNAL PACK

DO NOT SCALE

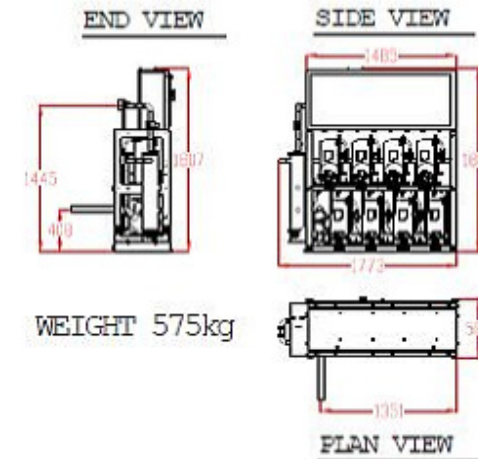

WEIGHT 575kg

EQUIPMENT	SUPPLY REQ	QUANTITY
2 DOOR FREEZER	13AMP 1 PHASE	1
HOT SELF SERVE	32AMP 1 PHASE	1
INTERNAL HT PACK	125AMP 3 PHASE	1
UNOX OVEN	32AMP 3 PHASE	1
BAKE FRESH OVEN	32AMP 3 PHASE	1
BWS CABINET	13AMP 1 PHASE	1
AS YOU GO	13AMP 1 PHASE	1

NOTE: 2.2m MIN. DOOR HEIGHT REQUIREMENT
FOR BATTER THRO DOORS & EXTERNAL DOOR